

Republic of the Philippines
ENERGY REGULATORY COMMISSION
San Miguel Avenue, Pasig City



IN THE MATTER OF THE
APPLICATION FOR AUTHORITY
TO DEVELOP, OWN AND
OPERATE DEDICATED POINT-
TO-POINT LIMITED FACILITIES
TO CONNECT TO THE
TRANSMISSION SYSTEM OF
THE NATIONAL GRID
CORPORATION OF THE
PHILIPPINES (NGCP), WITH
PRAYER FOR PROVISIONAL
AUTHORITY

ERC CASE NO. 2014-110 MC

MIRAE ASIA ENERGY CORP.
(MAEC),

Applicant.

X-----X

DOCKETED
Date: NOV 04 2014
By: *[Signature]*

ORDER

On September 5, 2014, the Mirae Asia Energy Corp. (MAEC) filed an application for authority to develop, own and operate dedicated point-to-point limited facilities to connect to the transmission system of the National Grid Corporation of the Philippines (NGCP), with prayer for provisional authority.

In the said application, MAEC alleged, among others, the following:

1. It is a power generation company duly organized and existing under and by virtue of the laws of the Republic of the Philippines, with principal office address at P1-08 Makati Palace Hotel, P. Burgos corner Caceres St., Brgy. Poblacion, Makati City. It may be served orders and other legal process through its undersigned counsel;

2. It is a power generation company organized pursuant to the EPIRA and other applicable laws. Its primary purpose is to engage in the business of development and construction of electrical power plants utilizing renewable energy resources such as solar photovoltaic and hydro resources;¹
3. It is a registered renewable energy developer of the Department of Energy (DOE) with a service contract for the exploration, development and utilization of solar energy resource in Currimao, Ilocos Norte;²
4. In its 2013 Supply-Demand Outlook, the Department of Energy (DOE) recognized the growing demand for power in the Philippines. For the Luzon Grid, the DOE projects the energy demand to increase at an average annual growth rate (AAGR) of 4.13 percent, from 7,969 MW in 2012 to 10,693 MW in 2020 and will increase further to 16,477 MW in 2030.” Based on the foregoing, the grid still needs 8,100 MW of additional capacities of 6,000 MW base-load plant and 2,100 MW peaking plants to meet the electricity demand and the required reserve margin of the grid;³
5. To help address the need for additional capacity in the Luzon Grid, it will design, engineer, procure, construct, supply, start-up, test, commission, own, operate, and maintain an approximately 20 MW solar power plant (Project) to be located at Brgy. Paguludan-Salindeg, Currimao, Ilocos Norte. The Project is projected to be completed and energized on February 28, 2015;
6. It has already secured the endorsement of the affected local governments for the Project.⁴ It has likewise obtained an Environmental Compliance Certificate for the Project;⁵

¹ Copies of MAEC's Certificate of Incorporation, Amended Articles of Incorporation and By-Laws are attached hereto as **Annexes “A”, “A-1” and “A-2”** and made integral part hereof.

² A copy of MAEC's Certificate of Registration as an RE Developer is attached hereto as **Annex “B”** and made an integral part hereof.

³ A copy of the Department of Energy's (“DOE”) 2013 Supply-Demand Outlook (please see Figure: Luzon Grid Supply-Demand Outlook, 2012-2030, p. 2) is attached hereto as **Annex “C”** and made an integral part hereof.

⁴ Copies of Resolution No. 2012-04 issued by the Sangguniang Barangay of Brgy. Paguludan-Salindeg, Resolution No. 2012-03-07 issued by Sangguniang Bayan of Currimao, and Resolution No. 109-2012 issued by Sangguniang Panlalawigan of Ilocos Norte are attached as **Annexes “D” to “D-2”** respectively, and made integral parts hereof.

⁵ A copy of the Environmental Compliance Certificate is attached as **Annex “E”** and made an integral part hereof.

7. To test, commission and dispatch its generating facility, soon after completion, it proposes to connect the Project to the transmission system of the National Grid Corporation of the Philippines (NGCP) through a dedicated point-to-point limited interconnection facility (the Transmission Line) to be developed by MAEC;⁶
 - 7.1 It intends to connect the Transmission Line to NGCP's 69 kV Currimao Substation. The Transmission Line will be a 69 kV, Single Circuit transmission line consisting of 336.4 MCM ACSR conductors equipped with Optical Fiber Ground Wire ("OPGW").⁷ The Transmission Line will consist of approximately 10.5 kilometers;
 - 7.2 The proposed interconnection of the Project to the Ormoc Substation is as follows:

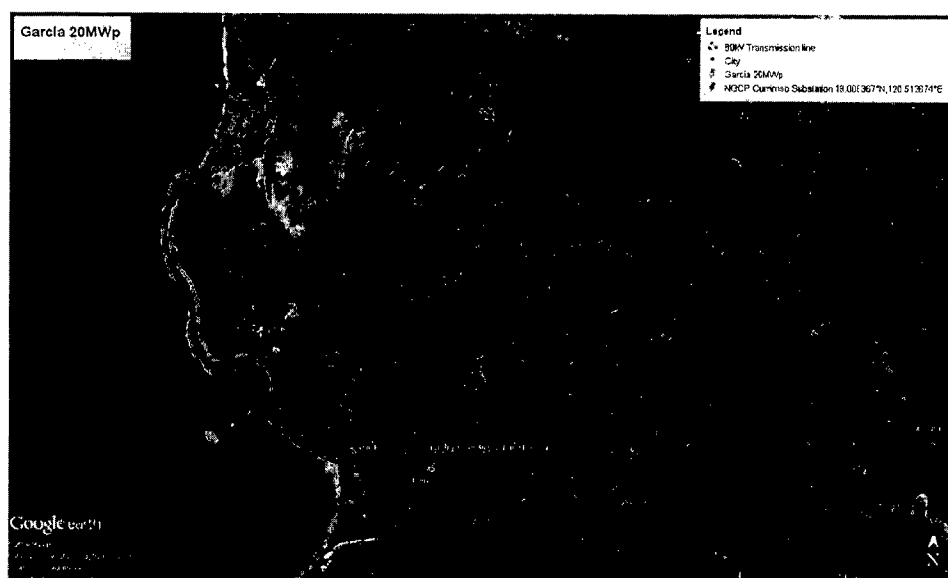

8. The construction of the Transmission Line will take approximately twenty (20) weeks from initial pre-construction works. Consistent with the projected date of energization of the Project, the Transmission Line is targeted to be completed by January 2015.⁸ The estimated cost for the Transmission Line is Sixty Three Million Seven

⁶ A copy of the description and scope of the project denominated as Project Description is attached as **Annex "F"** and made an integral part hereof.

⁷ A copy of the conceptual engineering design denominated as Transmission Line Design is attached as **Annex "G"** and made an integral part hereof.

⁸ A copy of the Project Schedule Gantt chart is attached as **Annex "H"** and made an integral part hereof.

Hundred Fifteen Thousand Seven Hundred Thirty-Two and 3/100 Pesos (Php63,715,732.03);⁹

9. The connection of the Project through the Transmission Line to the Currimao Substation is the most viable option among all the interconnection schemes it considered, recommended, and evaluated that will enable it to dispatch the Project's capacity when the need arises.¹⁰ A System Impact Study (SIS) on the proposed Transmission Line has been conducted and based on the results thereof, the said interconnection is technically feasible.¹¹ The SIS has also been reviewed and approved by NGCP.¹² It is in the process of entering into discussions for a connection agreement with NGCP;
10. The Project has already been considered in NGCP's 2013 Consultation Draft Report of the Transmission Development Plan (TDP);¹³
11. Section 9(f) of the Electric Power Industry Reform Act (EPIRA) provides:

"Xxx

A generation company may develop and own or operate dedicated point-to-point limited transmission facilities that are consistent with the TDP: Provided, that such facilities are required only for the purpose of connecting to the transmission system, and are used solely by the generating facility, subject to prior authorization by the ERC. Xxx"

12. In accordance with the requirement of Section 9(f) of the EPIRA, it hereby seeks the Commission's authorization to develop, own, and operate the Transmission Line, a dedicated point-to-point limited interconnection facility, to connect the Project to the NGCP Currimao Substation;

⁹ A copy of the detailed cost estimates denominated as Transmission Line Cost is attached as **Annex "I"** and made an integral part hereof.

¹⁰ The discussion of the options/alternatives considered in lieu of the proposed Transmission Line is found in the Project Description attached as **Annex "F"**.

¹¹ A copy of the System Impact Study is attached as **Annex "J"** and made integral parts hereof.

¹² A copy of NGCP's Review of the Third Party System Impact Study is attached as **Annex "K"** and made an integral part hereof.

¹³ A copy of NGCP's 2013 Transmission Development Plan Consultation Draft Report, Volume I Major Network Development (Please see Table 4.4(a): List of Luzon Generation Capacity Addition, pp. 25-26) is attached as **Annex "L"** and made an integral part hereof.

13. The proposed Transmission Line meets the requirements provided in Section 9 of the EPIRA and the relevant regulations issued by the Commission as follows:
 - 13.1 The Transmission Line is a dedicated point-to-point limited interconnection facility whose sole purpose is to connect the Project to the Grid through the NGCP Ormoc Substation and is considered a "Connection Asset" under ERC Resolution No. 16, Series of 2011 (ERC Resolution);
 - 13.2 The Transmission Line will be exclusively used by the MAEC for the operations of the Project and will not serve any end-user;
 - 13.3 The Transmission Line is part of the 2013 TDP of the NGCP;¹⁴
 - 13.4 The Transmission Line is technically feasible;¹⁵ and
 - 13.5 It has the technical and financial ability to develop, construct, operate, and maintain the Transmission Line;

The Transmission Line is a dedicated point-to-point transmission facility and will be used exclusively by MAEC

14. To reiterate, the Transmission Line is designed for the sole purpose of connecting the Project to the Grid through the NGCP Currimao Substation. The single-line diagram of the proposed interconnection shows that the Transmission Line will be exclusively used by it and is not designed and configured to serve end-users.

The single-line diagram of the Transmission Line is illustrated in Figure 2 below:

¹⁴ Supra note 13.

¹⁵ Supra note 11.

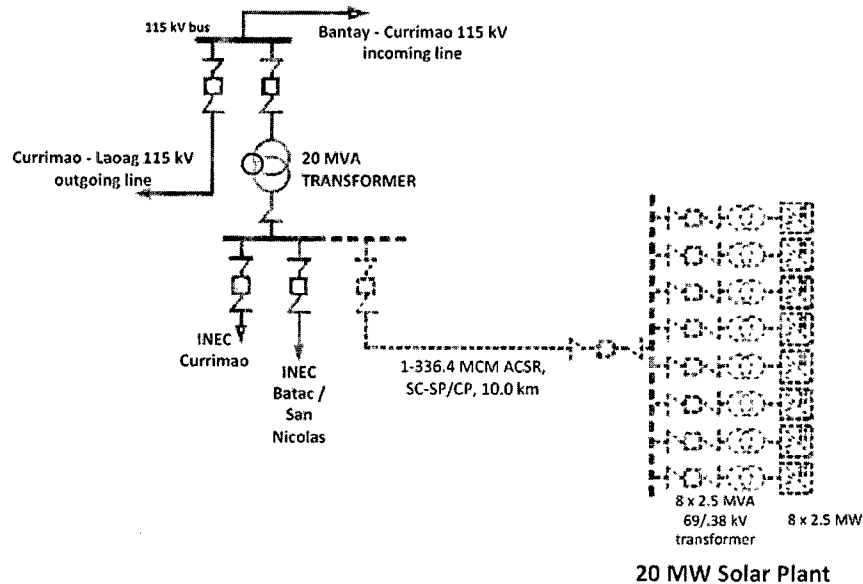

15. The Transmission Line is also classified as a “Connection Asset” under the ERC Resolution since it is primarily designed to connect the Project to the Grid and will be used for the conveyance of electricity from the Project to the Grid.¹⁶ If the Transmission Line is taken out of the transmission system of NGCP, such disconnection will only affect MAEC and will have no effect on the Grid, or other connected customers;

The Transmission Line is consistent with the 2013 Transmission Development Plan (TDP)

16. The proposed Transmission Line is consistent with the TDP. The TDP refers to the program for managing the transmission system through efficient planning for the expansion, upgrading, rehabilitation, repair, and maintenance, formulated by the DOE and implemented by the NGCP. The 2013 TDP identifies the Project as one of the proposed generating plants in Luzon.¹⁷ The 2013 TDP states:

¹⁶ Resolution Adopting the Amended Rules on the Definition and Boundaries of Connection Assets for Customers of Transmission Provides, ERC Resolution No. 16, Series of 2011, Annex A, § 2, p.1.

¹⁷ Supra note 13.

Xxx 4.4 Generation Capacity Addition

This section shows the proposed generating plants in Luzon, Visayas and Mindanao Grids

based on DOE List of Private Sector-Initiated Power Projects as of December 13, 2013 (the 2012 PDP Update).

The DOE has also provided the list of generating plants that already have clearance to undertake System Impact Study (SIS) but are not included yet in the said 2012 PDP Update since the reports on the status of their development are not yet submitted. This list will fall under the new classification named the Prospective Projects.

Thus, there will be three generation project classifications, as follows:

- a. Committed - These are projects that have service contracts in place, are in the development/commercial stage and have financial close already.
- b. Indicative – Projects with service contracts, in the development/commercial stage but with no bank financing yet.
- c. Prospective – Projects with DOE clearance to undertake SIS and service contracts and on the predevelopment stage. These projects are not included in the official list of DOE's "Private Sector-Initiated Power Projects".

...

Table 4.4(a):
List of Luzon Generation Capacity Addition
(DOE List of Private Sector-Initiated Power Projects
as of December 13, 2013)

Comm. Year	Proposed Generation Facility	Capacity (MW)	Location
2014	Mirae Currimao Solar	20	Currimao, Ilocos Norte

17. Recently, the Project was included as one of the indicative projects in the DOE List of Private Sector-Initiated Power Projects for Luzon as of February 28, 2014.¹⁸ The said DOE list reads in part:

Committed / Indicative	Name of the Project	Project Proponent	Location	Rated Capacity (MW)	Project Status	Target Testing and Commissioning
	SOLAR					
Indicative	Currimao Solar Photovoltaic Power Project	Mirae Asia Energy Corporation.	Currimao, Ilocos Norte	20	- Awarded with Solar Energy Service Contract (SESC No. 2012-08-020) on 19 Sept. 2012; - Secured Memorandum of Agreement with Provincial Government of Ilocos Norte for the utilization of the land; Completed feasibility study; Conducted Third Party SIS, currently under review by NGCP; Acquired ECC from DENR, CNO from NCIP; Provincial, Municipal and Barangay Resolutions of Support, EPC Contract with LG CNS Co. Ltd., and proofs of negotiations/certifications with financial institutions for project financing; -Secured Clearance from Doe for the conduct of GIS on 11 October 2012; -Conducted Groundbreaking Ceremony on Nov. 2012; Acquired the DOE – Certificate of Confirmation of Commerciality on 12 Jul 2013; -Total project cost is US\$51.9Million; -Negotiations with lenders is on-going.	August 2014

¹⁸ A copy of the DOE List of Private Sector-Initiated Power Projects (Luzon), as of February 28, 2014 is attached as **Annex "M"** and made an integral part hereof; please see p. 11 thereof.

**The Transmission Line
is technically feasible**

18. The SIS conducted by EAGLE Engineering Solutions Corporation shows that the connection of the Project through the Transmission Line to be developed, owned, and operated by it, to the Currimao Substation is technically feasible.¹⁹
- 18.1 The SIS concluded that connection of the proposed 20MW Project to the Luzon Grid is technically acceptable and may, in fact, reduce the loadings of the 230/115 kV transformer in Laoag and San Esteban as well as associated transmission facilities,²⁰ and
- 18.2 On December 9, 2013, NGCP approved the SIS submitted by it for the Project;²¹
19. It proposed the Transmission Line connection to the Currimao Substation because of its proximity for the connection of the Project. Between the options considered for the route of the Transmission Line, the option traversing and utilizing the city road was found to be more feasible and economical;²²
20. It is also in the process of finalizing the Facility Study and have sent the Facility Study Report for review with the NGCP for the Connection Agreement;
21. It has likewise ensured that the design and technical specifications for the Transmission Line are consistent with the standards of the Philippine Grid Code;²³

**MAEC has the technical
and financial capability
to develop, construct,
operate, and maintain
the Transmission Line**

¹⁹ Supra note 11.

²⁰ Id.

²¹ Supra note 12.

²² Supra note 6.

²³ Supra note 7.

22. It has the technical capability to develop the Transmission Line.
- 22.1 The Transmission Line will be constructed by Tri-Ohms Engineering, a company established by Engr. Geronimo Perey, specializes in rehabilitation, rewinding, testing and commissioner of power transformer. It is also engaged in the hauling and installation of power transformers and HV equipments;²⁴ and
- 22.2 It likewise has the financial capability to undertake the development and construction of the Transmission Line. The development and construction of the Project and the Transmission Line will be funded by it through equity from shareholders and debt financing.²⁵
23. Since the development and construction of the Transmission Line will be solely funded by it and its shareholders and the Transmission Line will be exclusively used by it for the operations of the Project and will not serve any end-user, the Transmission Line will not have an impact on the transmission rates currently being charged by the NGCP;
24. Once completed, it will undertake the operations and maintenance of the Transmission Line through the NGCP and it will subsequently fund the operations of the Transmission Line from its generation sales;²⁶
25. It also undertakes to file an application for a Certificate of Compliance with the Commission;
26. The foregoing clearly shows that the proposed Transmission Line complies with Section 9 of the EPIRA and the relevant regulations of the Commission;

²⁴ A copy of the Company Profile of Tri-Ohms Engineering with a list of projects undertaken is attached as **Annex "N"** and made an integral part hereof.

²⁵ A copy of MAEC's 2011, 2012 and 2013 Audited Financial Statements are attached as **Annex "O", "O-1" and "O-2"** and made an integral part hereof.

²⁶ A copy of MAEC's Financial Feasibility Study and Projected Financial and Economic Cost Analysis are attached as **Annex "P" and "Q"** and made an integral part hereof.

Motion for Provisional Authority and Allegations in Support of Prayer for Provisional Authority

27. Rule 14 of the Commission's Rules of Practice and Procedure authorizes the issuance of a provisional authority or an interim relief prior to a final decision, provided that the facts and circumstances warrant the issuance of the same;
28. It prays that the Commission provisionally authorize the development, ownership, and operation of the Transmission Line considering that the facts, circumstances and the magnitude of the opportunity costs entailed by any further delay in the interconnection of the Project warrants the issuance of a Provisional Authority.
 - 28.1 It hopes to be able to complete development and construction of the facilities at the soonest possible time in order to be able to dispatch electric power supply to the transmission system of NGCP;
 - 28.2 The Project is one of the energy projects under Republic Act No. 9513 or the Renewable Energy Act of 2008, which aims to accelerate the development and utilization of the country's renewable energy sources. Thus, it is in the interest of the government to help RE developers such as MAEC to achieve commerciality and commence operations at the soonest practicable time;
 - 28.3 The construction of the Transmission Line is a pre-requisite for the testing and commissioning, and ultimately, its commercial operations. The Project is projected to be completed and energized on February 28, 2015. Consistent with this timeline, it intends to complete the development and construction of the Transmission Line by January 2015;
 - 28.4 Moreover, the use of solar energy reduces the country's dependence on fossil fuels, which not only minimizes harmful carbon green house emissions in the environment but also reduces the country's exposure to price fluctuations in the international markets;

28.5 Further, given the immediate need for additional capacity by 2015, the completion of the Project and the Timeline within the timeframe is critical to ensure that additional capacity will be available to the Luzon Grid in a timely manner; and

28.6 The issuance of a provisional authority is also critical in light of the DOE's first-come, first-served policy on the Feed-in Tariff ("FIT") allocation. It is thus necessary for it to secure a provisional authority to immediately commence with the construction of the Transmission Line in order to avail of the initial FIT, which is essential to its economic viability.

A copy of the Affidavit executed by Gerald Rubis Pagobo, in support of the prayer for the issuance of provisional authority is attached to the application and made an integral part thereof as **Annex "R"**;

29. It is in such context that it prays that provisional authority be immediately issued for the development and construction of the proposed Transmission Line; and

30. It prays that the Commission:

- a. ISSUE an order provisionally authorizing it to implement the development, ownership and operation of the Transmission Line; and
- b. APPROVE the application for authority to develop, own and operate the Transmission Line.

Finding the said application to be sufficient in form and in substance with the required fees having been paid, the same is hereby set for initial hearing, expository presentation, pre-trial conference and evidentiary hearing on **November 25, 2014 (Tuesday) at ten o'clock in the morning (10:00 A.M.) at the ERC Hearing Room, 15th Floor, Pacific Center Building, San Miguel Avenue, Pasig City.**

MAEC is hereby directed to cause the publication of the attached Notice of Public Hearing, at its own expense, once (1x) in a newspaper of general circulation in the Philippines, with the date of

the publication to be made not later than ten (10) days before the scheduled date of initial hearing. It is also directed to inform the consumers within its franchise area, by any other means available and appropriate, of the filing of the instant application, its reasons therefor, and of the scheduled hearing thereon.

Let copies of the application, this Order and the attached Notice of Public Hearing be furnished the Office of the Solicitor General (OSG), the Commission on Audit (COA), and the Committees on Energy of both Houses of Congress. They are hereby requested, if they so desire, to send their duly authorized representatives at the scheduled hearing.

Likewise, let copies of this Order and the attached Notice of Public Hearing be furnished the Offices of the Governor of the Province of Ilocos Norte, Mayors of the City of Makati and Municipality of Currimaos, Ilocos Norte for the appropriate posting thereof on their respective bulletin boards.

MAEC is hereby directed to furnish all those making requests therefor with copies of the application and its attachments, subject to reimbursement of reasonable photocopying costs.

On the date of the initial hearing, MAEC must submit to the Commission its written Compliance with the jurisdictional requirements attaching therewith, methodically arranged and duly marked, the evidences on the actual posting and publication of the Notice of Public Hearing consisting of certifications issued to that effect, signed by the afore-mentioned Governor, Mayors and or their duly authorized representatives, bearing the seals of their offices, and the affidavit of the Editor or Business Manager of the newspaper where the said Notice of Public Hearing was published together with the complete issue of the said newspaper, and such other proofs of compliance with the requirements of the Commission.

MAEC and all interested parties are directed to submit, at least five (5) days before the date of initial hearing and pre-trial conference, their respective Pre-trial Briefs containing, among others:

- a) A summary of admitted facts and proposed stipulation of facts;
- b) The issues to be tried or resolved;

- c) The documents or exhibits to be presented, stating the purposes and proposed markings therefore; and
- d) The number and names of the witnesses, with their written testimonies in an individual affidavit form, to be attached to the Pre-trial Brief.

Failure of MAEC to submit the required Pre-trial Brief and Judicial Affidavits of its witnesses within the prescribed period shall be a ground for cancellation of the scheduled hearing, and the resetting of which shall be six (6) months from said date of cancellation.

As part of the pre-trial conference, MAEC must also be prepared to make an expository presentation of its application, aided by whatever communication medium that it may deem appropriate for the purpose, in order to put in plain words and explain, for the benefit of the consumers and other concerned parties, what the application is all about and the reasons and justifications being cited in support thereof.

SO ORDERED.

Pasig City, November 3, 2014.

FOR AND BY AUTHORITY
OF THE COMMISSION:

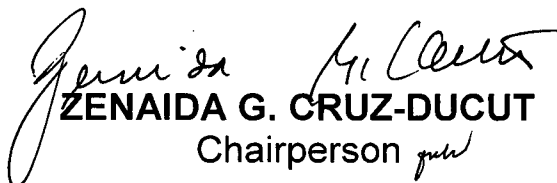
ZENAIDA G. CRUZ-DUCUT
Chairperson *gud*

Copy Furnished:

1. **PUNO AND PUNO**
Attn: Attys. Rogelio D. Puno, Jr., Kristie Auriel T. Enriquez
and Maria Gabriela C. Dorotan
Counsel for the Applicant
12th Floor, East Tower
Philippine Stock Exchange Center
Exchange Road, Ortigas Center, Pasig City
2. **MIRAE ASIA ENERGY CORP. (MAEC)**
P1-08 Makati Place Hotel
P. Burgos corner Caceres St.
Brgy. Poblacion, Makati City
3. **Office of the Solicitor General**
134 Amorsolo Street, Legaspi Village
Makati City, Metro Manila
4. **Commission on Audit**
Commonwealth Avenue
Quezon City, Metro Manila
5. **Senate Committee on Energy**
GSIS Bldg., Roxas Blvd., Pasay City
Metro Manila
6. **House Committee on Energy**
Batasan Hills, Quirino City, Metro Manila
7. **Office of the President-PCCI**
Philippine Chamber of Commerce and Industry (PCCI)
3RD Floor ECC Building
Sen. Gil Puyat Avenue, Makati City
8. **Office of the City Mayor**
Makati City
9. **Office of the Sangguniang Barangay**
Bgy. Paguludan-Salindeg, Currimao, Ilocos Norte
10. **Office of the Municipal Mayor**
Currimao, Ilocos Norte
11. **Office of the Provincial Governor**
Province of Ilocos Norte